

FLUGZEUGE DER SCHWEIZER FLIEGERTRUPPE VON 1936–1948

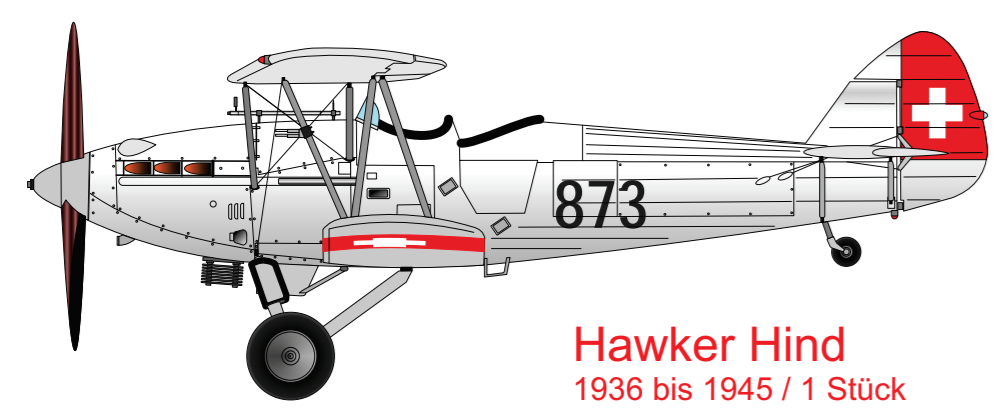

Hawker Hind
1936 bis 1945 / 1 Stück

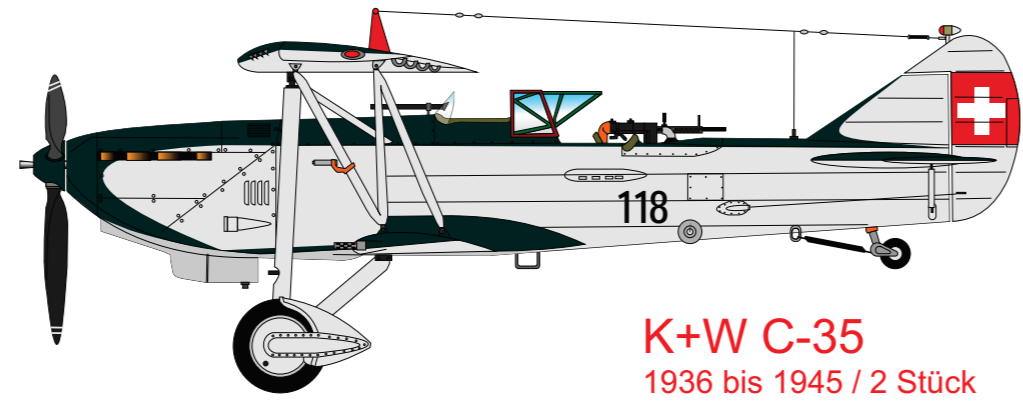

K+W C-35
1936 bis 1945 / 2 Stück

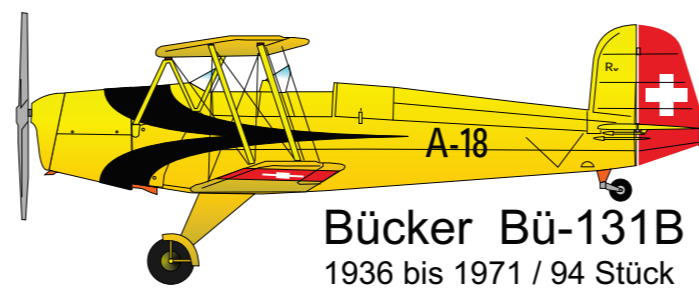

Bücker Bü-131B Jungmann
1936 bis 1971 / 94 Stück

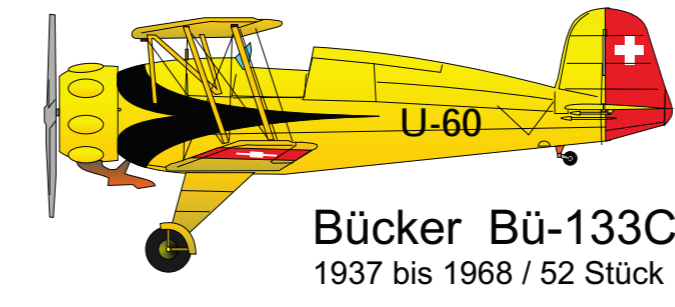

Bücker Bü-133C Jungmeister
1937 bis 1968 / 52 Stück

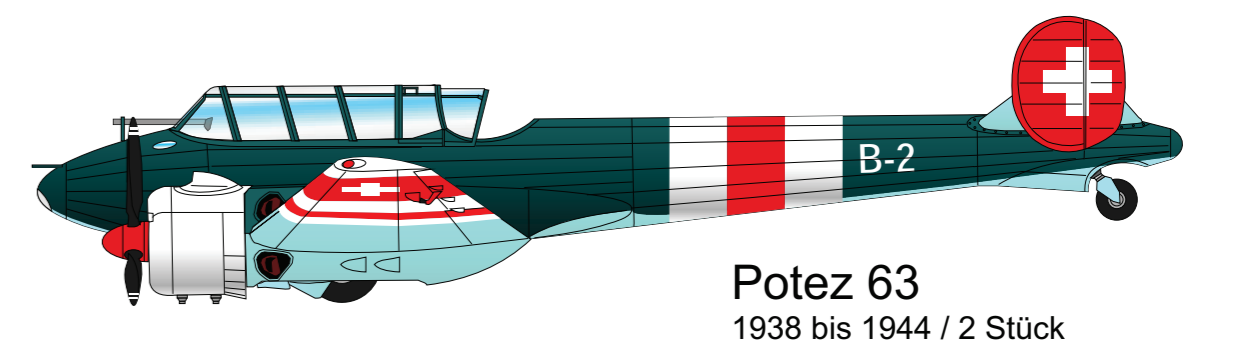

Potez 63
1938 bis 1944 / 2 Stück

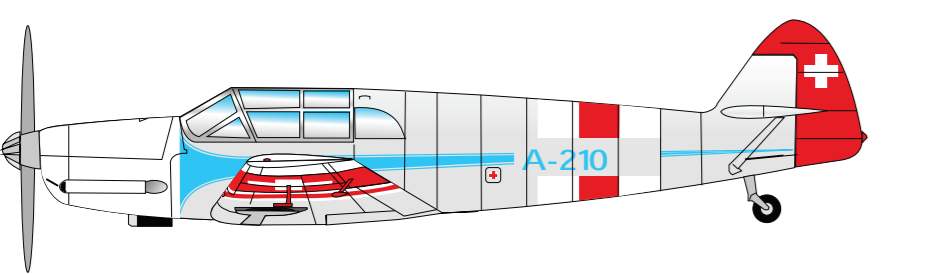

Messerschmitt BF-108B Taifun
1938 bis 1959 / 18 Stück

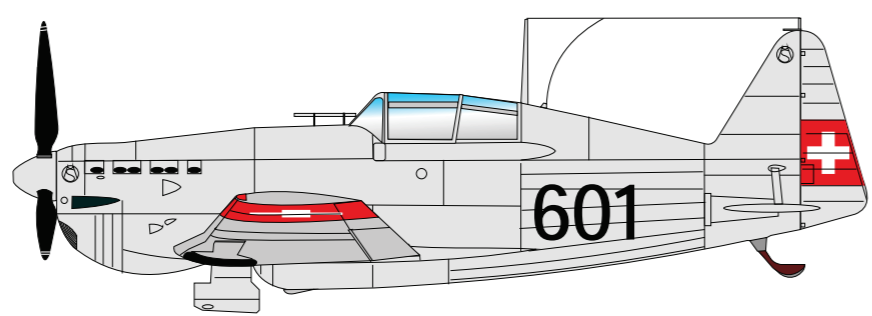

Morane-Saulnier MS-406C-1
1939 bis 1954 / 2 Stück

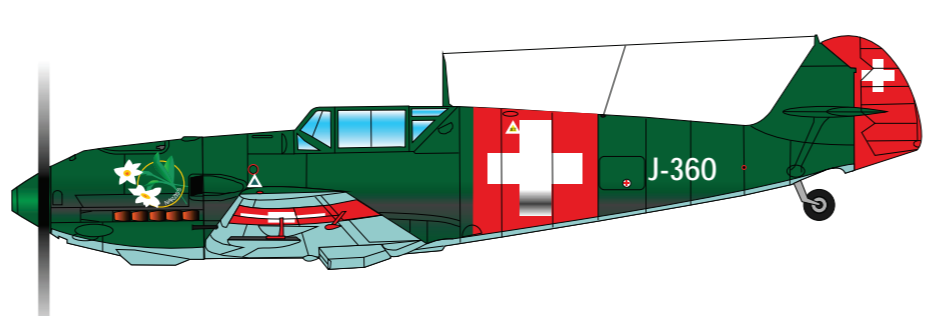

Messerschmitt BF-109E «Emil»
1939 bis 1948 / 89 Stück

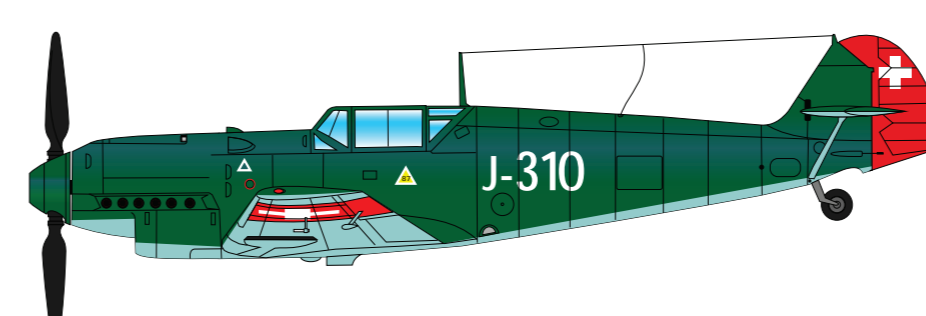

Messerschmitt BF-109D «David»
1939 bis 1949 / 10 Stück

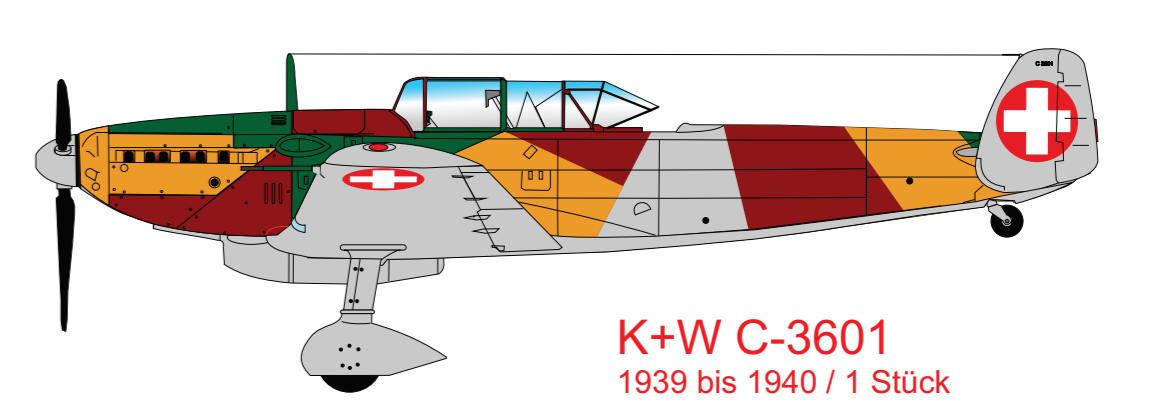

K+W C-3601
1939 bis 1940 / 1 Stück

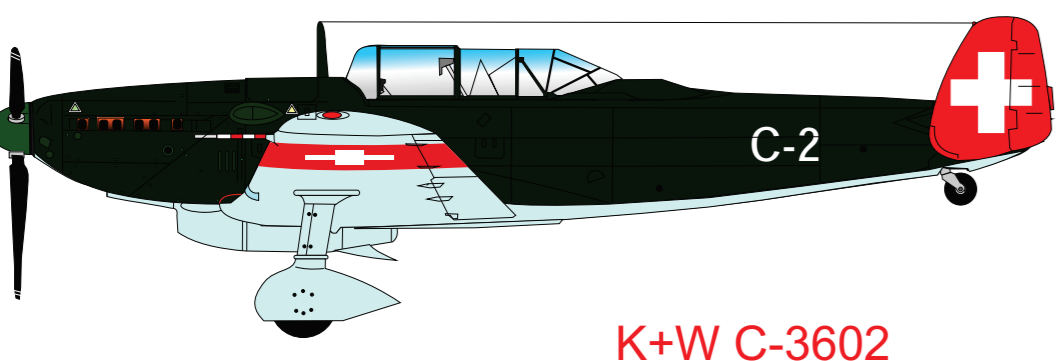

K+W C-3602
1939 bis 1940 / 1 Stück

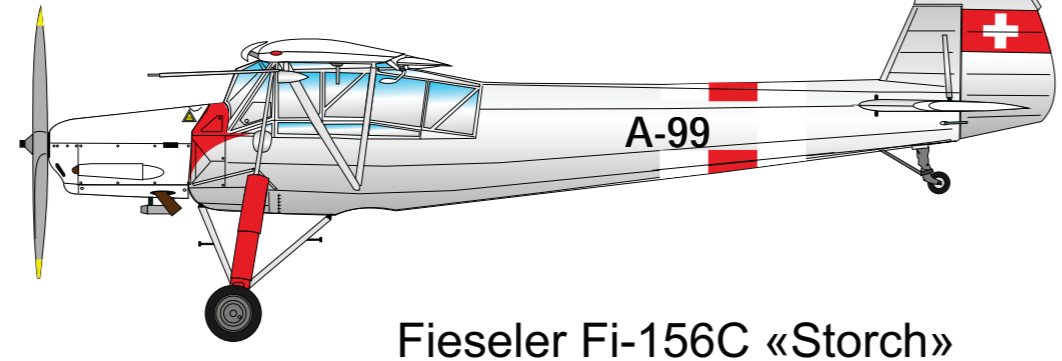

Fieseler Fi-156C «Storch»
1939 bis 1963 / 2 Stück

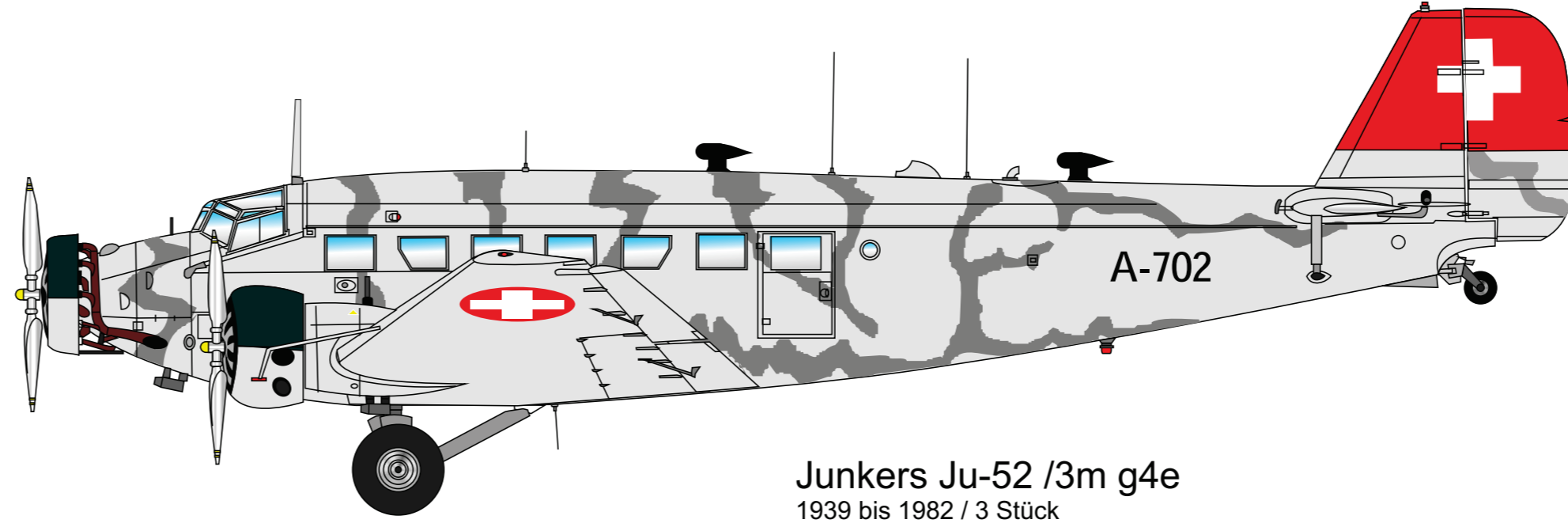

Junkers Ju-52 /3m g4e
1939 bis 1982 / 3 Stück

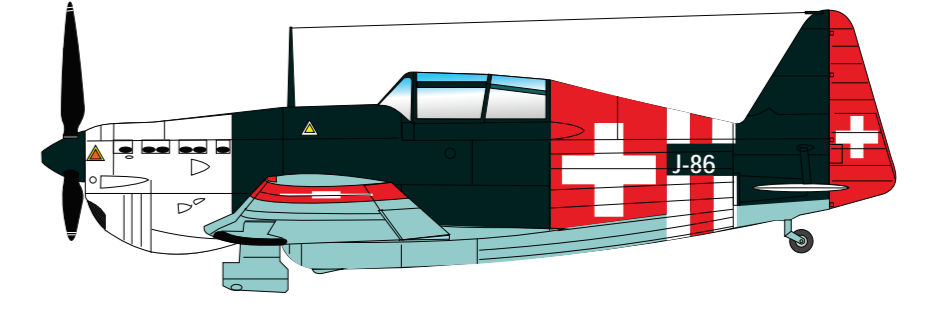

Morane D-3800
1940 bis 1954 / 82 Stück

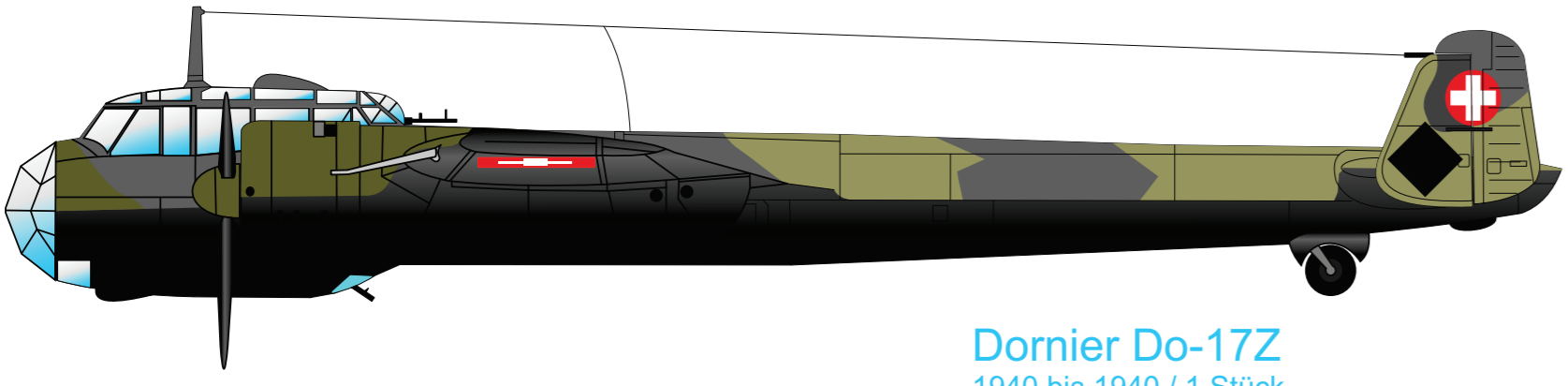

Dornier Do-17Z
1940 bis 1940 / 1 Stück

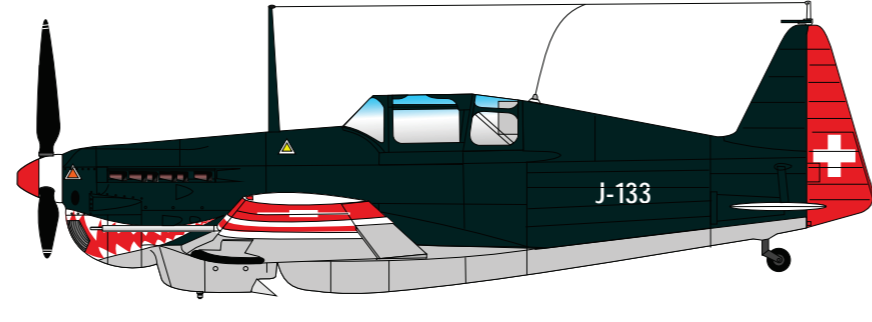

Morane D-3801
1940 bis 1959 / 207 Stück

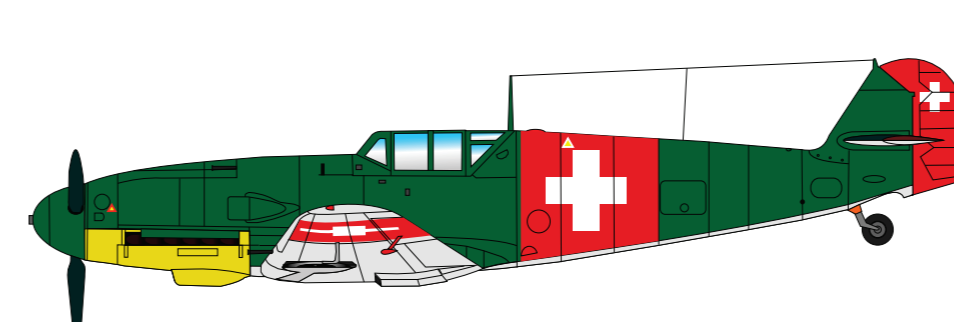

Messerschmitt BF-109F-4 «Fritz»
1942 bis 1948 / 2 Stück

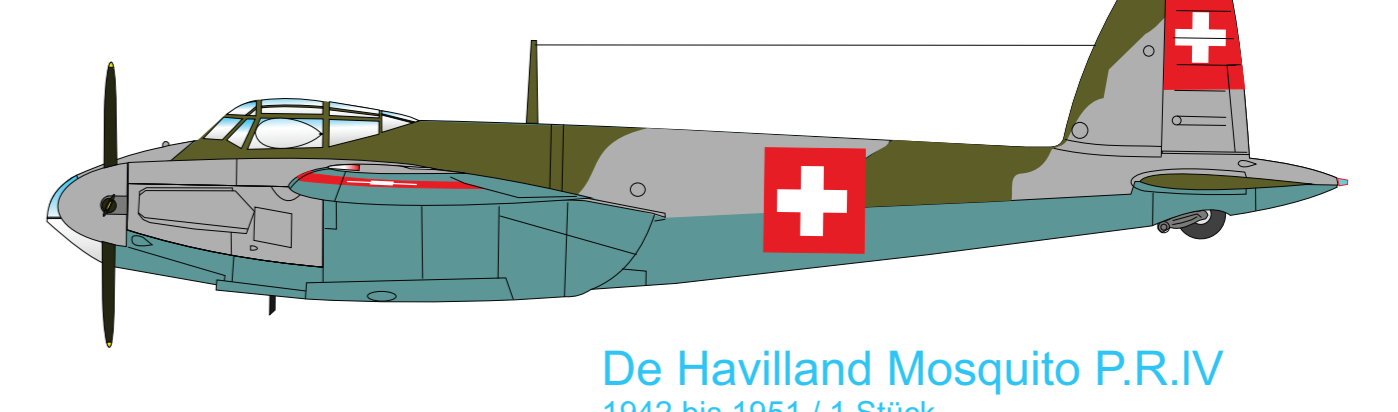

De Havilland Mosquito P.R.IV
1942 bis 1951 / 1 Stück

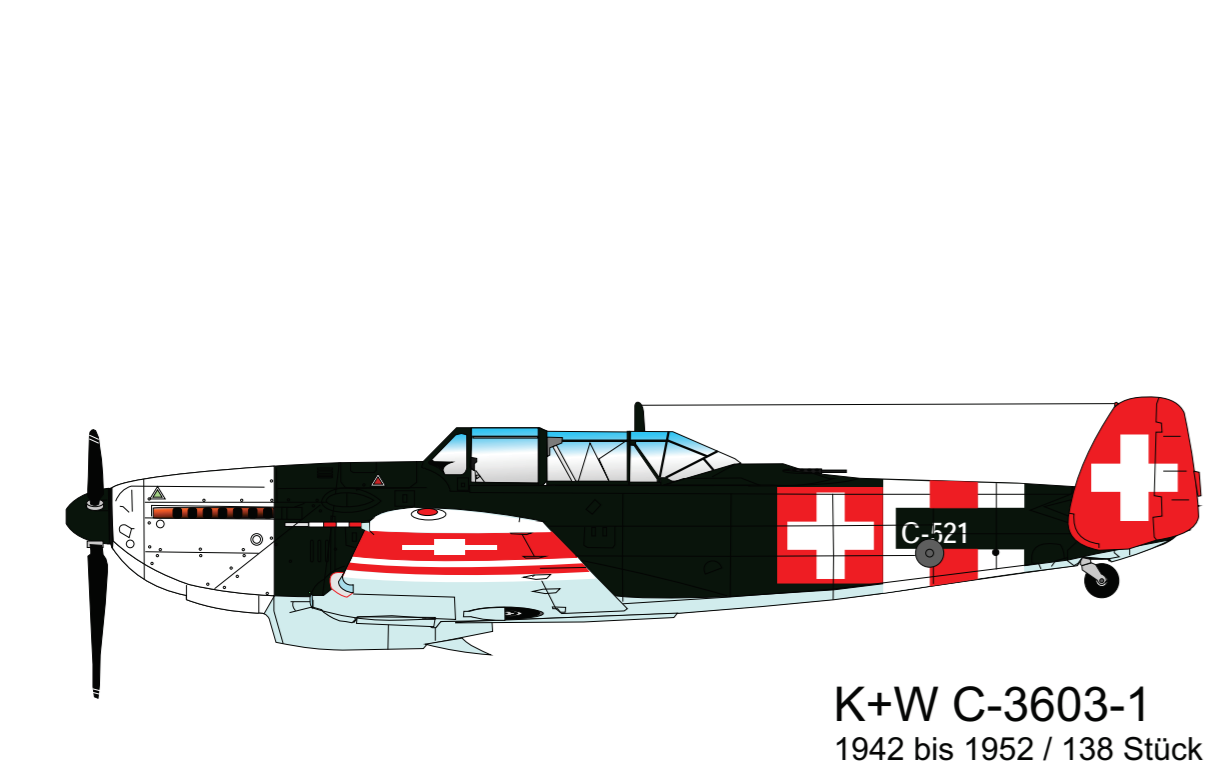

K+W C-3603-1
1942 bis 1952 / 138 Stück

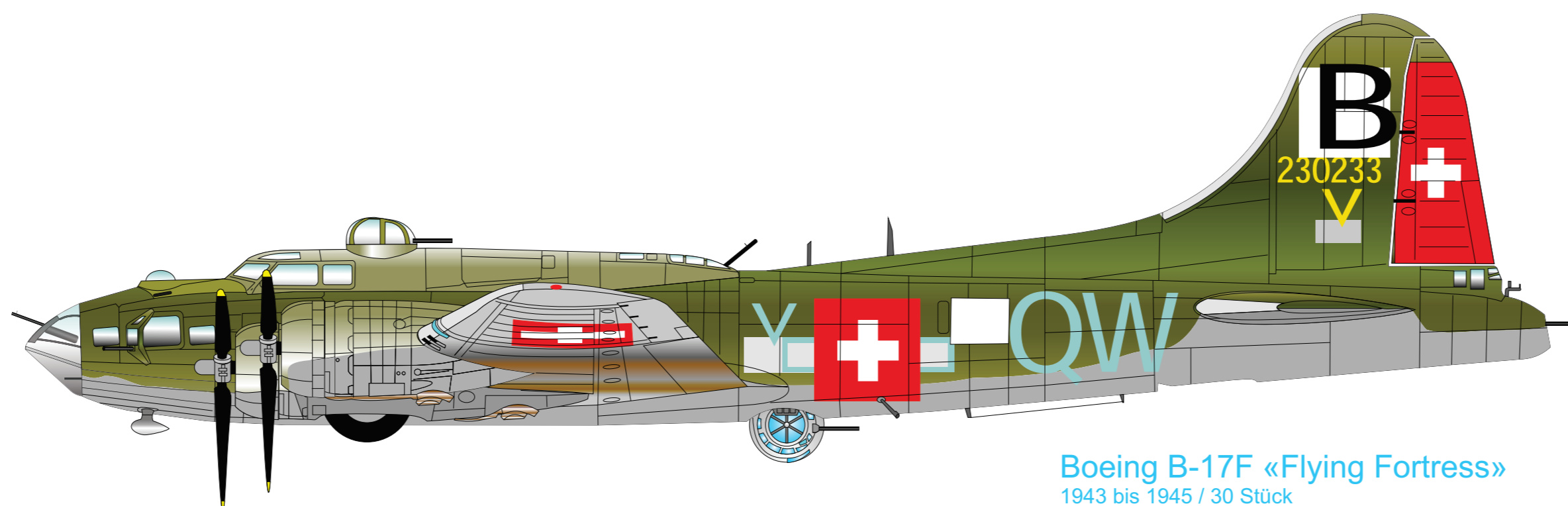

Boeing B-17F «Flying Fortress»
1943 bis 1945 / 30 Stück

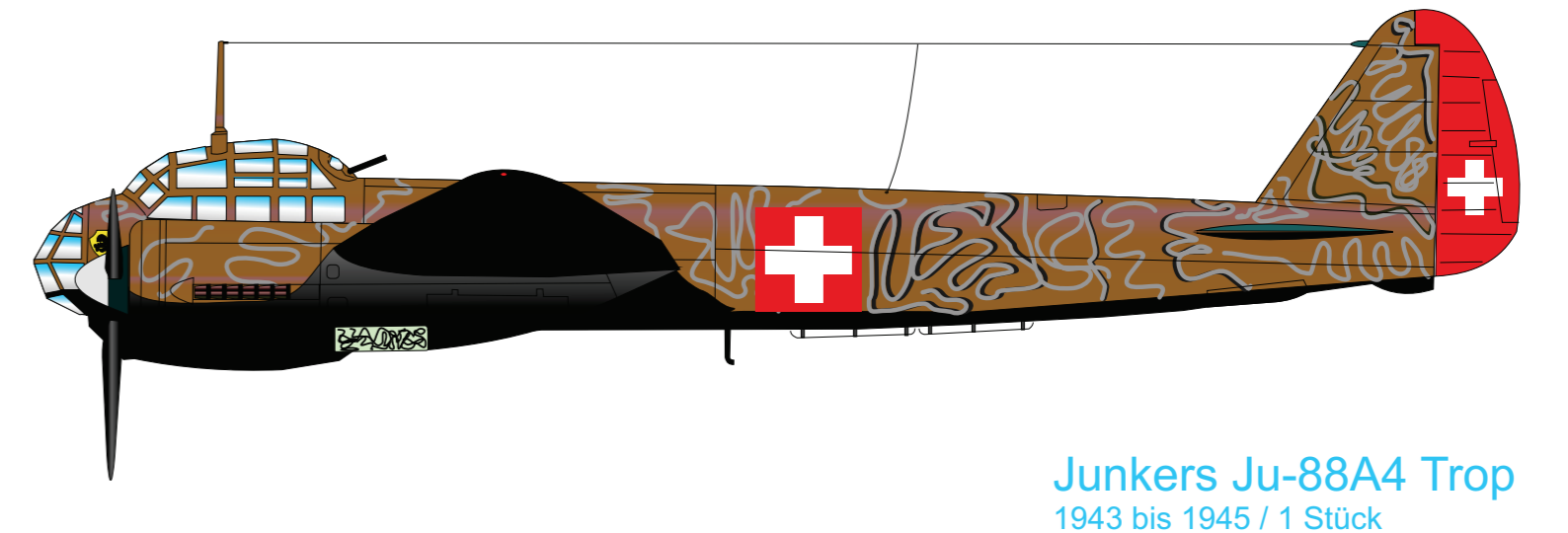

Junkers Ju-88A4 Trop
1943 bis 1945 / 1 Stück

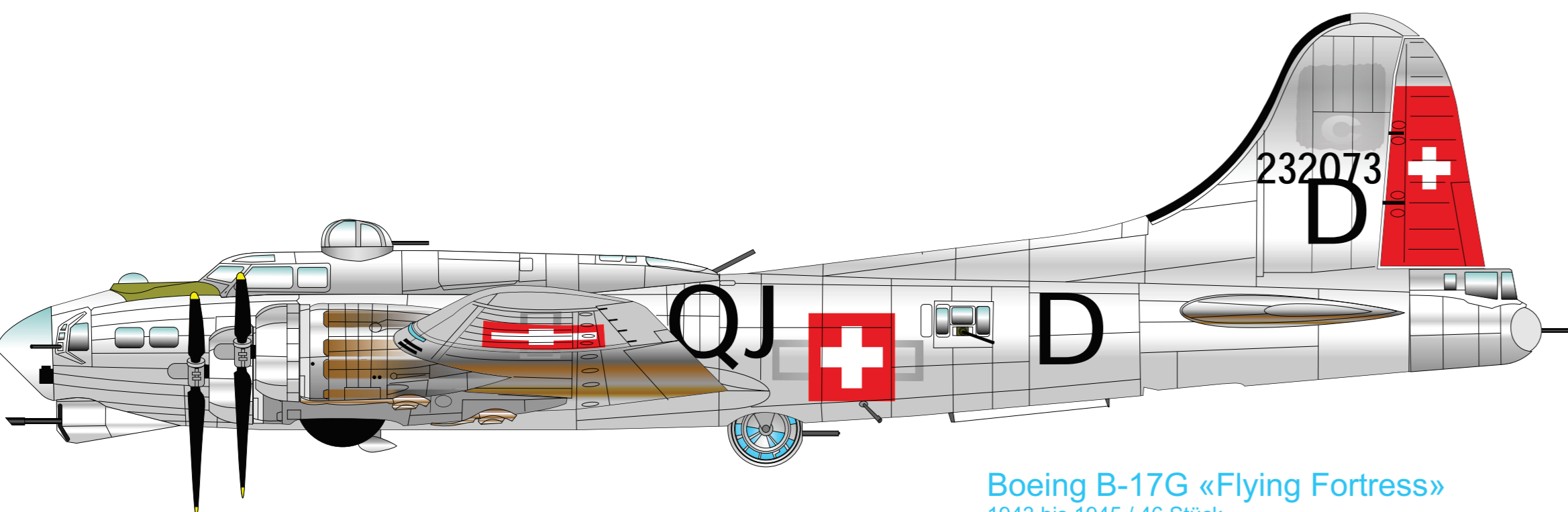

Boeing B-17G «Flying Fortress»
1943 bis 1945 / 46 Stück

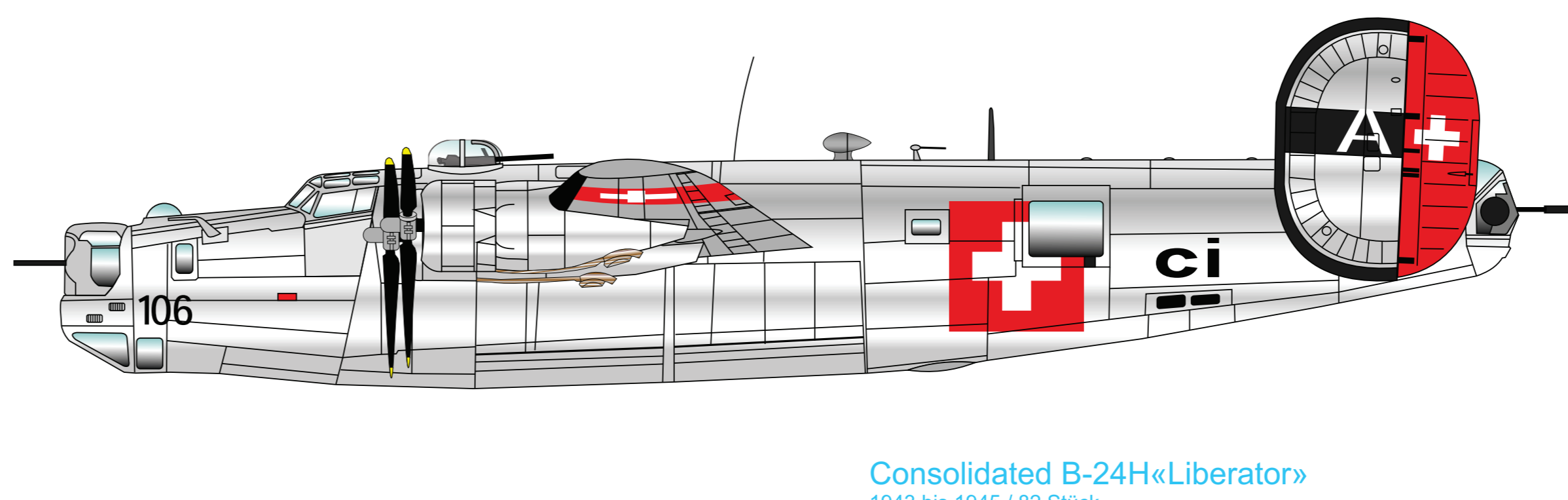

Consolidated B-24H«Liberator»
1943 bis 1945 / 82 Stück

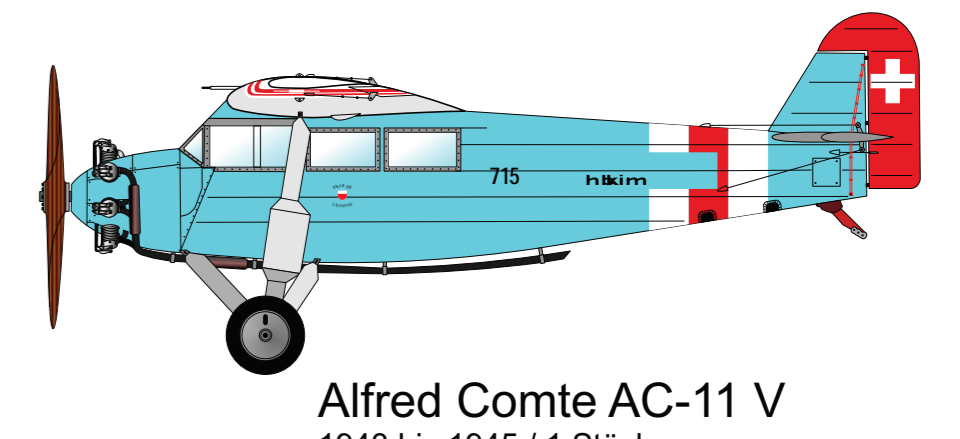

Alfred Comte AC-11 V
1943 bis 1945 / 1 Stück

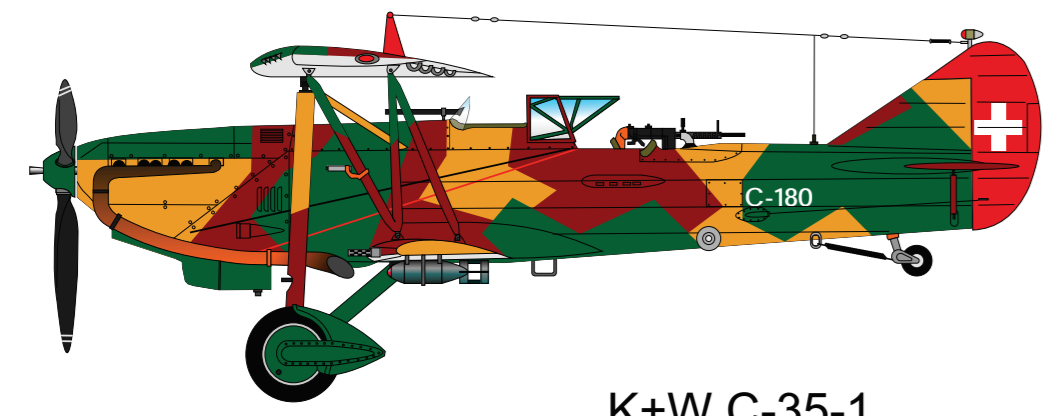

K+W C-35-1
1943 bis 1954 / 65 Stück

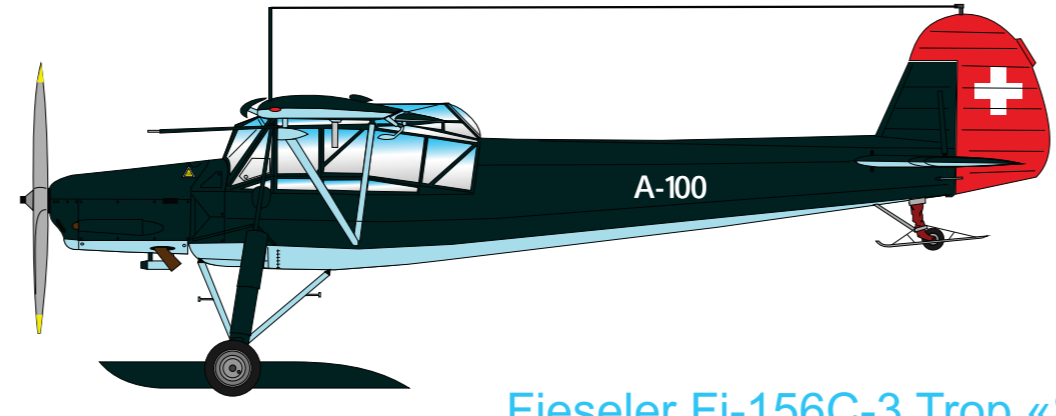

Fieseler Fi-156C-3 Trop «Storch»
1943 bis 1963 / 3 Stück



Fiat C.R. 42 Falco
1943 bis 1947 / 1 Stück

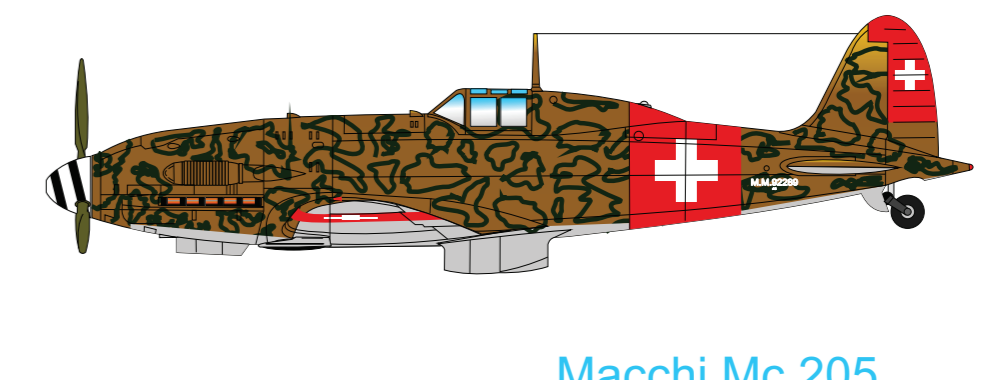

Macchi Mc.205
1944 bis 1947 / 1 Stück

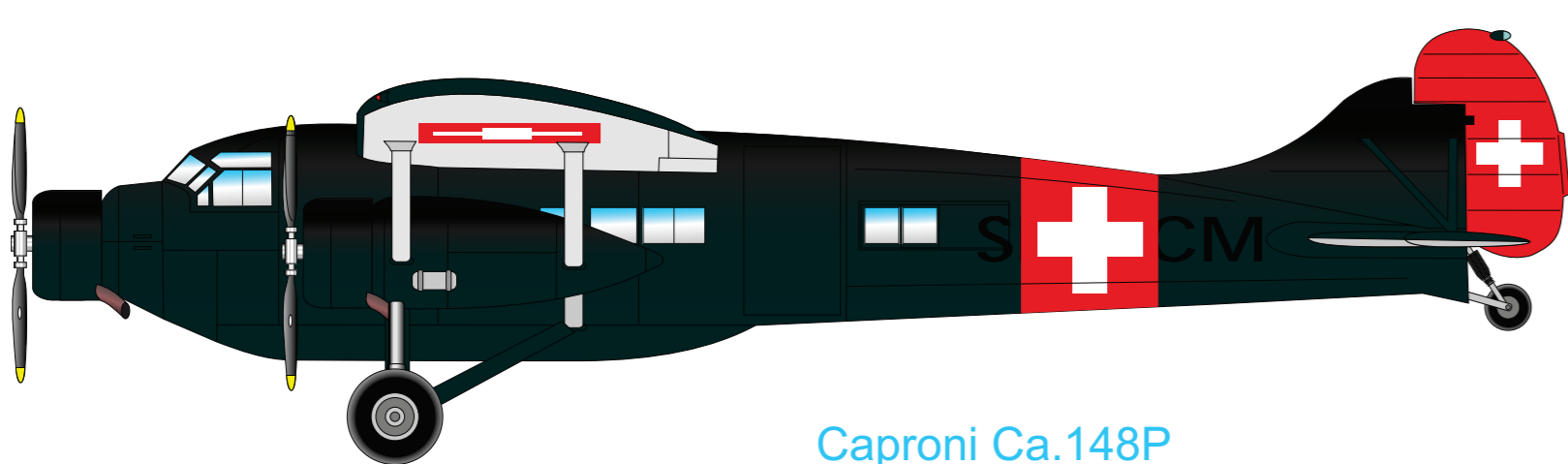

Caproni Ca.148P
1944 bis 1947 / 1 Stück

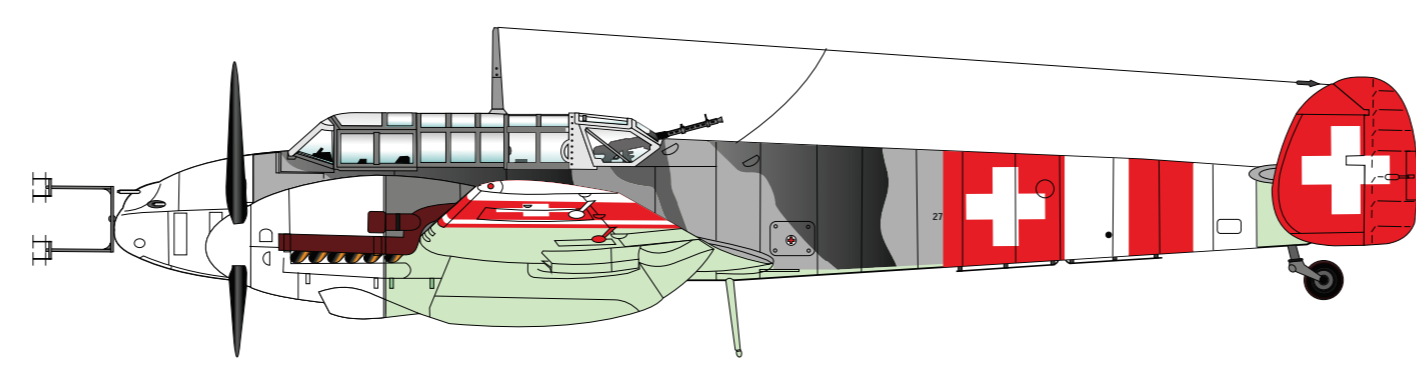

Messerschmitt Me-110G
1944 bis 1945 / 2 Stück

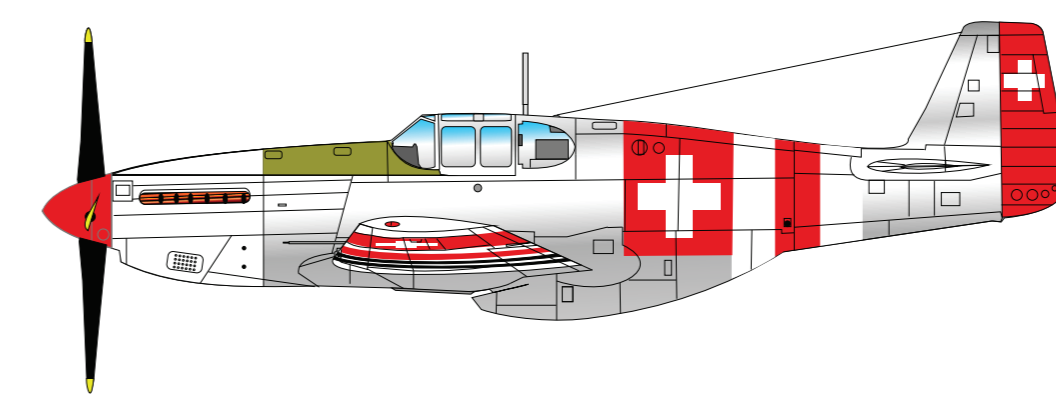

North American P-51B «Mustang»
1944 bis 1945 / 1 Stück

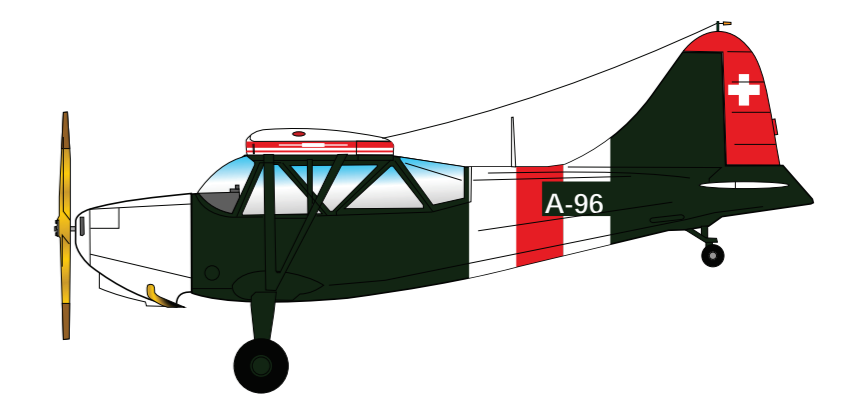

Stinson L-5A «Sentinel»
1944 bis 1945 / 1 Stück

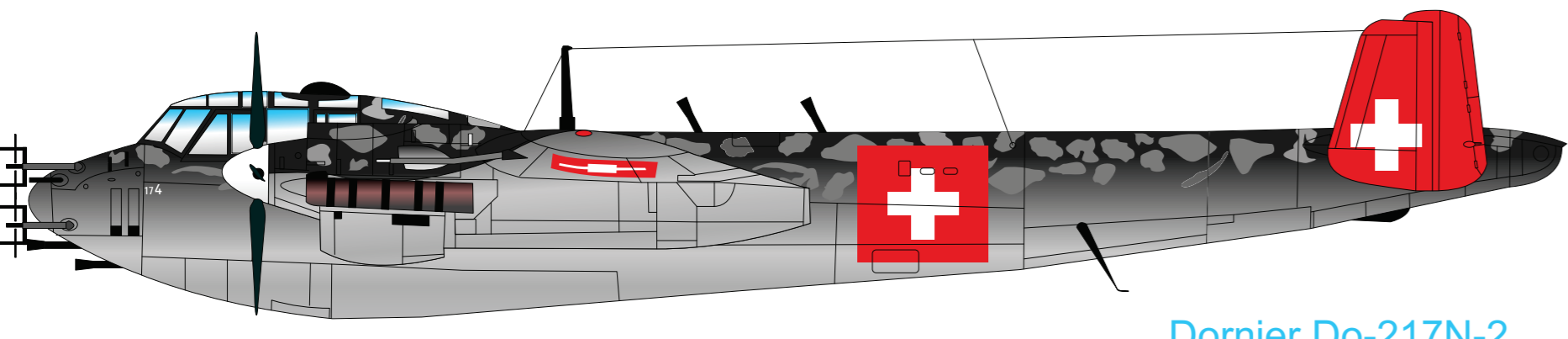

Dornier Do-217N-2
1944 bis 1945 / 1 Stück

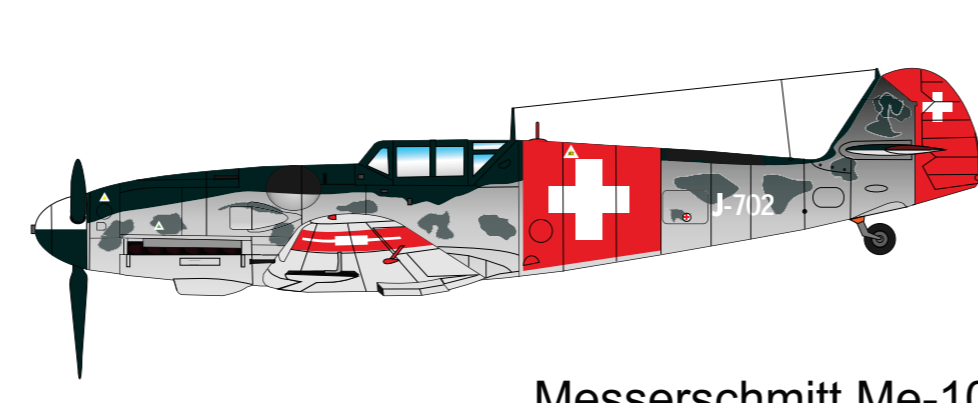

Messerschmitt Me-109G-6
1944 bis 1947 / 13 Stück

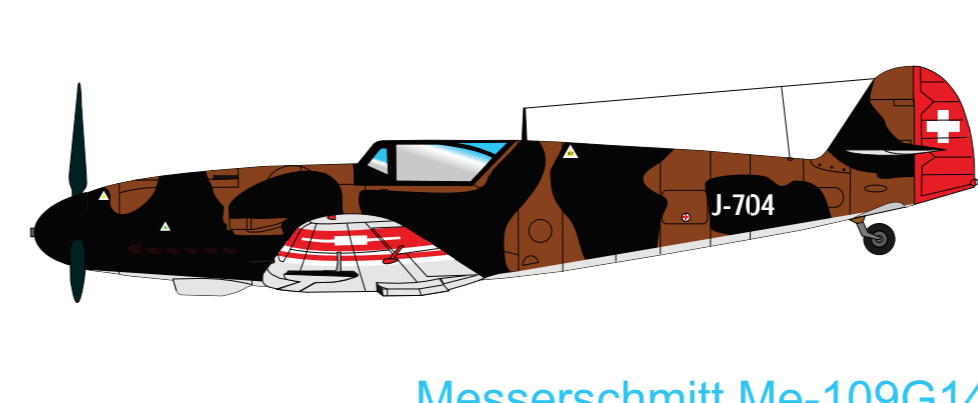

Messerschmitt Me-109G14
1944 bis 1948 / 2 Stück

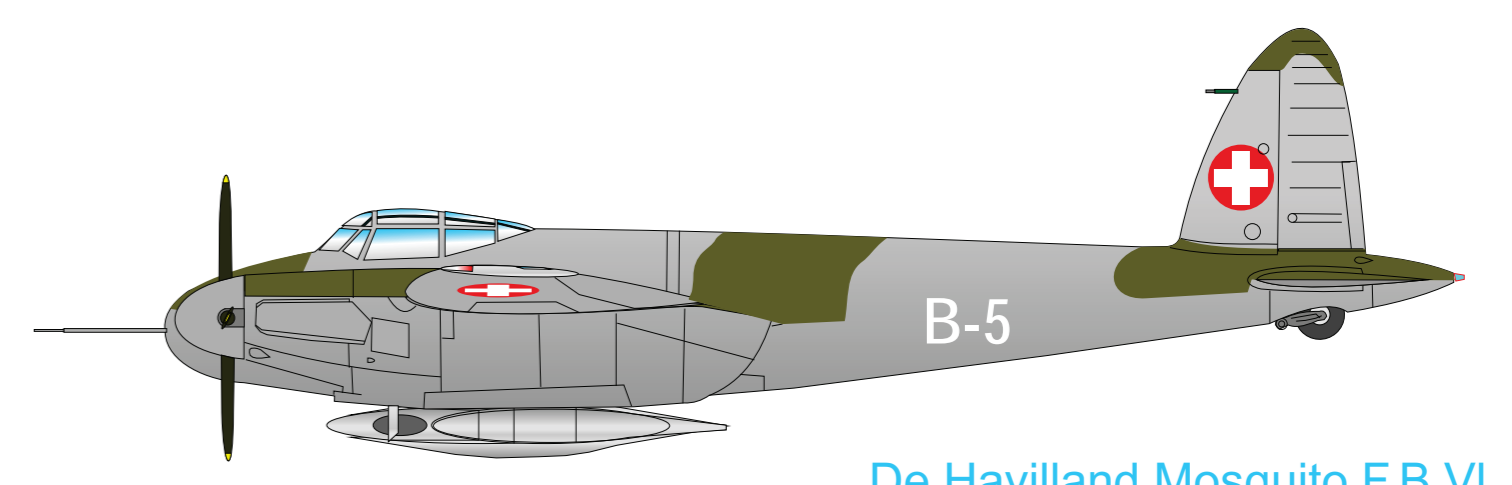

De Havilland Mosquito F.B.VI
1944 bis 1951 / 1 Stück

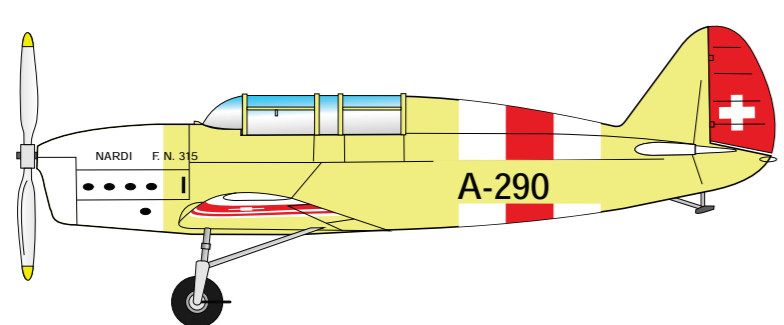

Nardi FN-315
1944 bis 1948 / 2 Stück

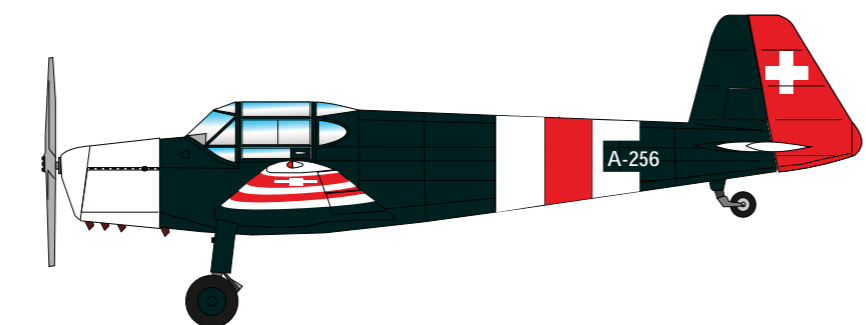

Bücker Bü-181 «Bestmann»
1944 bis 1956 / 7 Stück

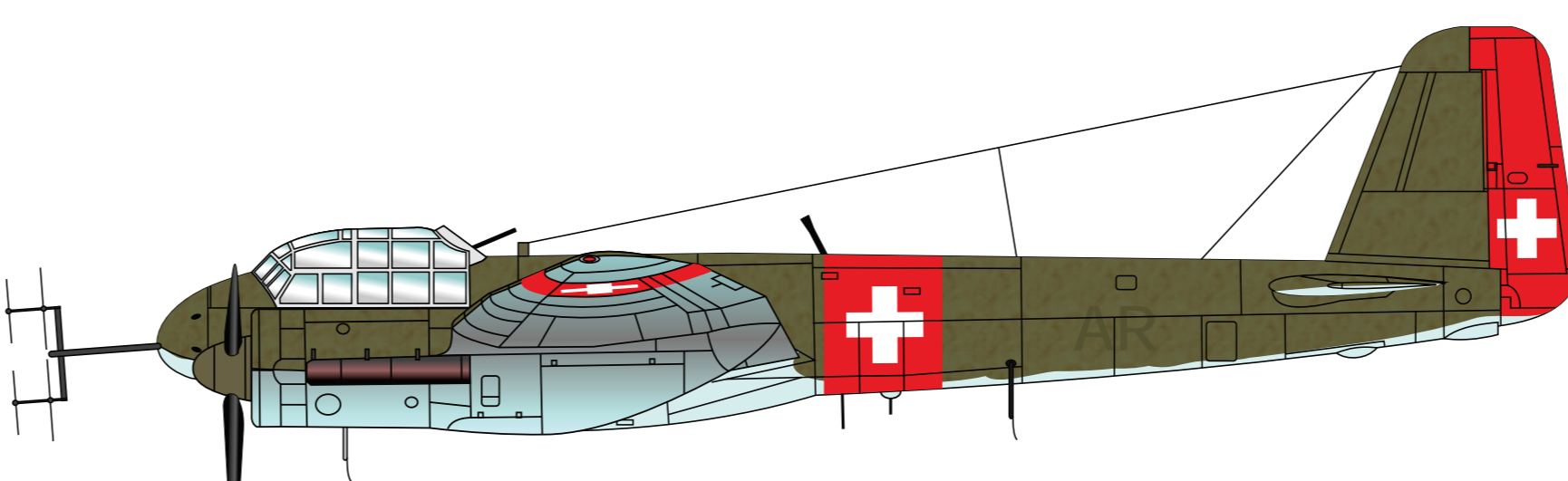

Junkers Ju-88G-6
1945 bis 1949 / 1 Stück

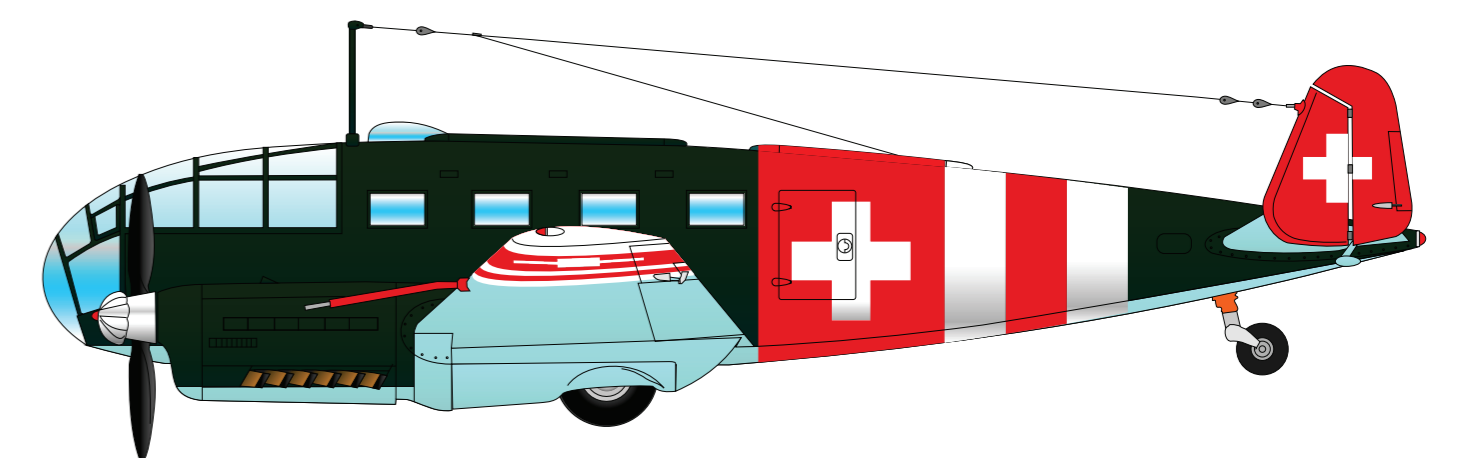

Siebel Si-204D-1
1945 bis 1955 / 1 Stück

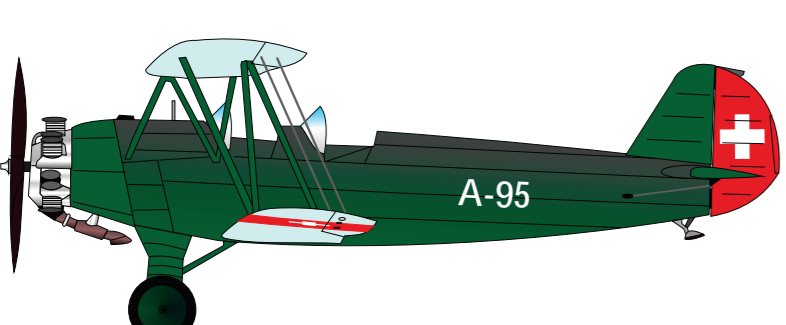

Focke-Wulf Fw-44F «Stieglitz»
1945 bis 1953 / 1 Stück

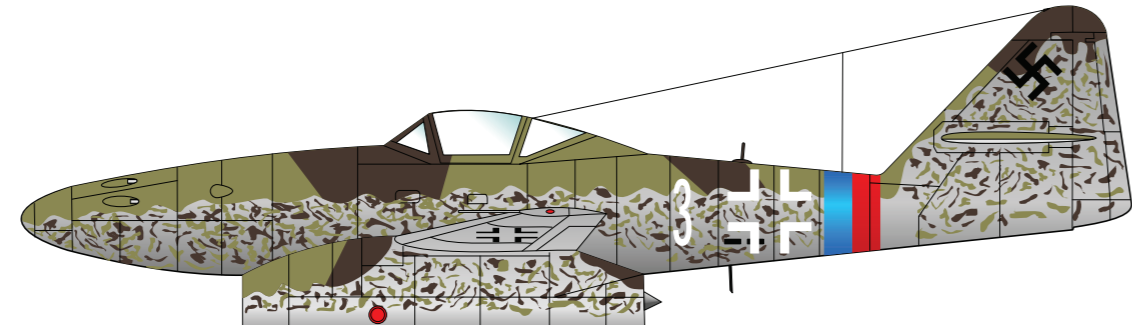

Messerschmitt Me-262A-1a
1945 bis 1957 / 1 Stück

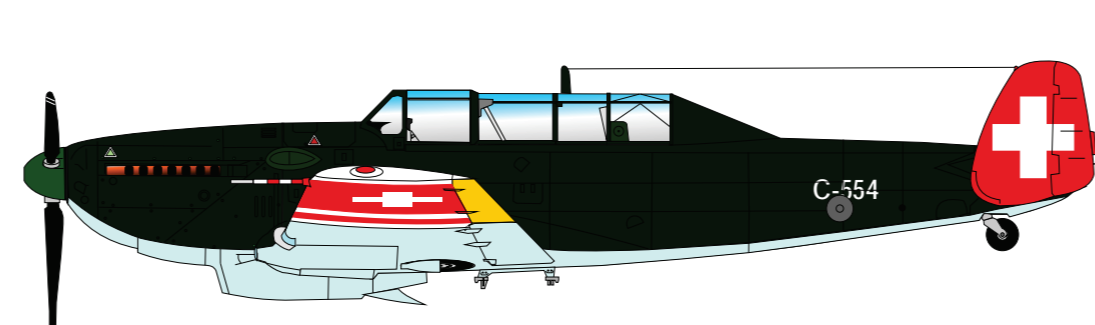

F+W C-3603-1Tr
1945 bis 1974 / 2 Stück

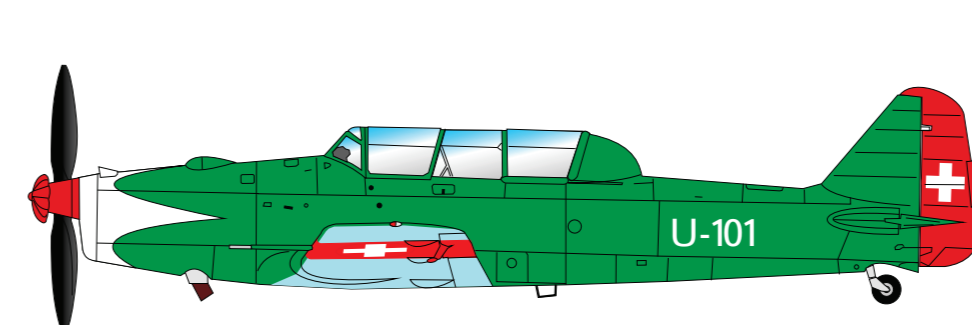

Pilatus P-2-01
1945 bis 1981 / 1 Stück

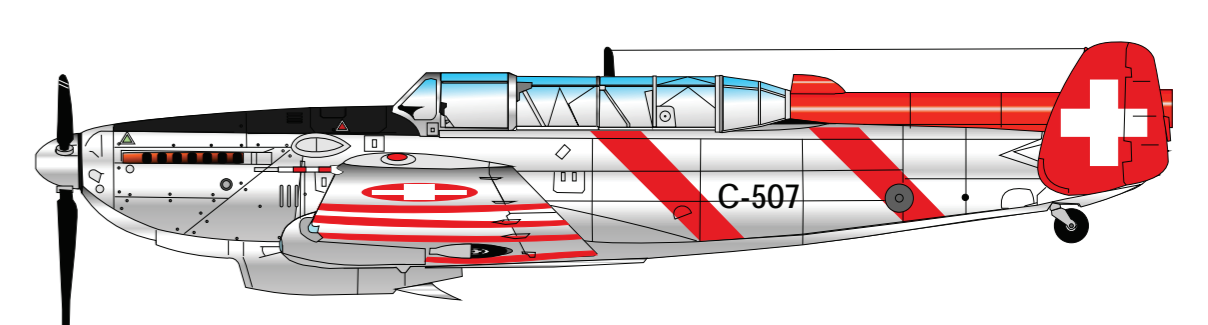

F+W C-3603-1Schlepp
1945 bis 1987 / 20 Stück

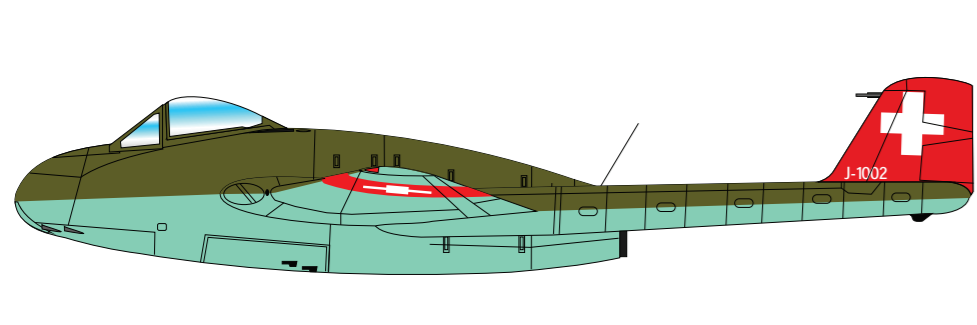

De Havilland Vampire Mk.1
1946 bis 1961 / 4 Stück

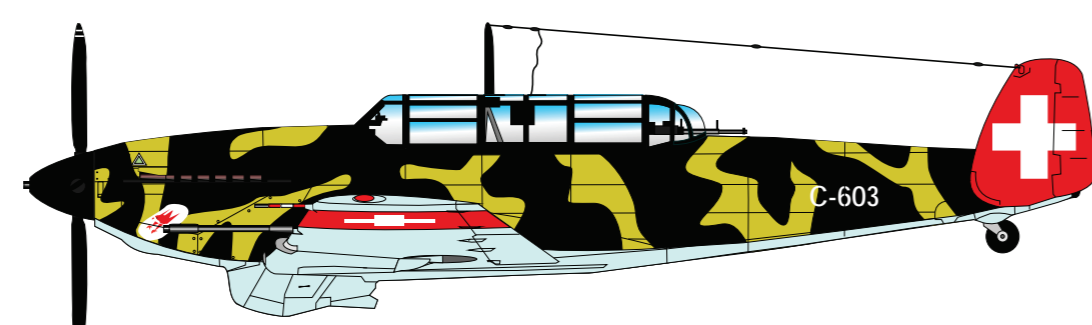

F+W C-3604
1947 bis 1956 / 13 Stück

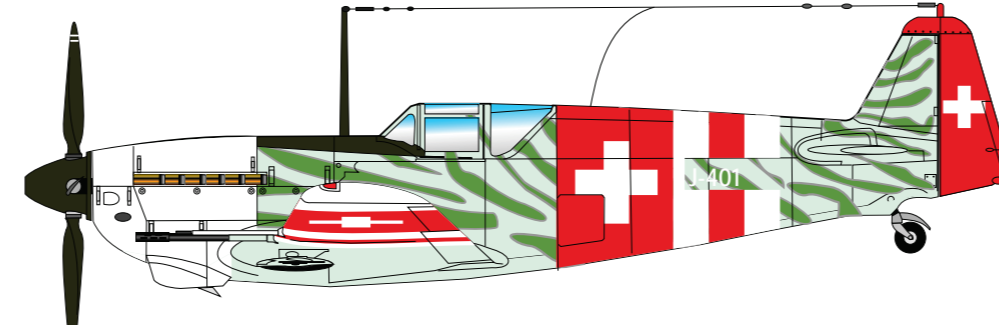

Morane D-3802
1947 bis 1956 / 1 Stück

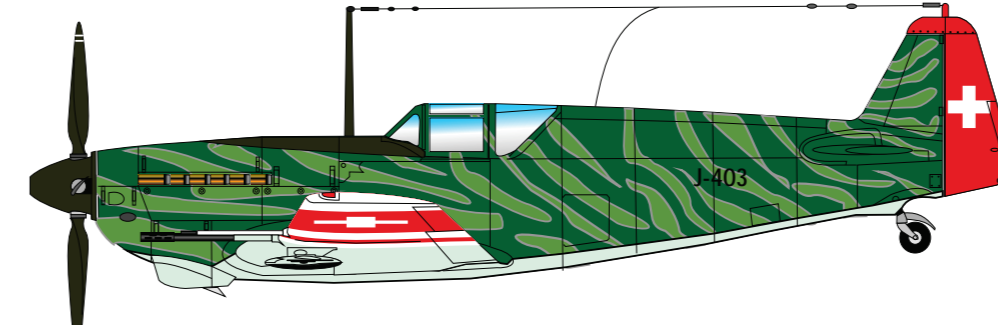

Morane D-3802A
1947 bis 1956 / 11 Stück

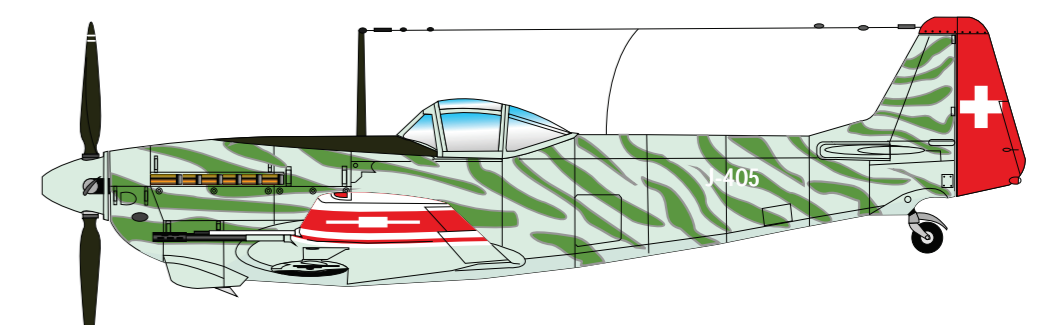

Morane D-3803
1947 bis 1956 / 1 Stück

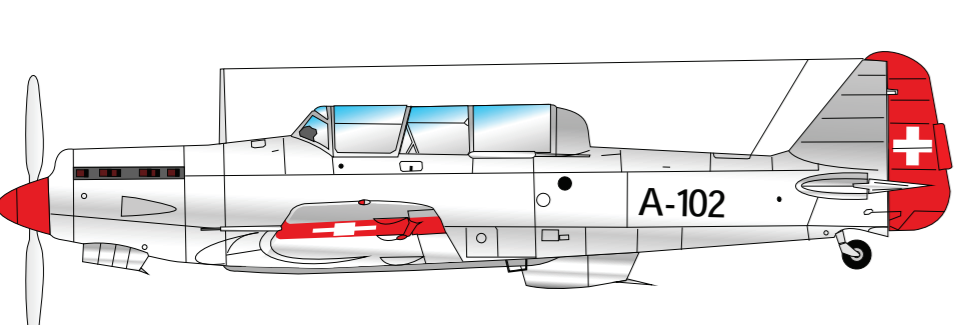

Pilatus P-2-03(04)
1947 bis 1962 / 2 Stück

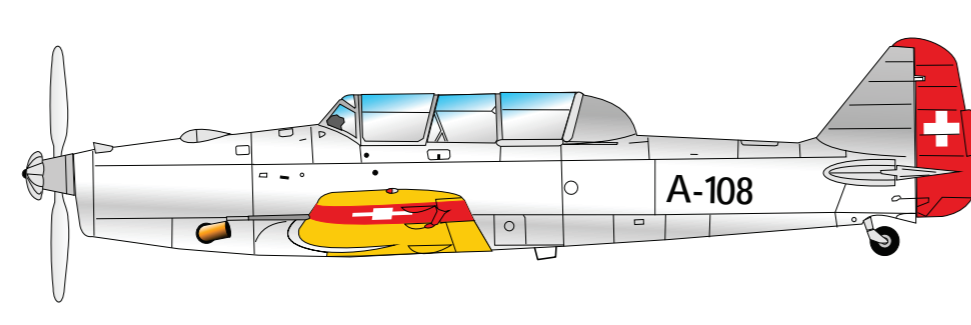

Pilatus P-2-05
1947 bis 1981 / 26 Stück

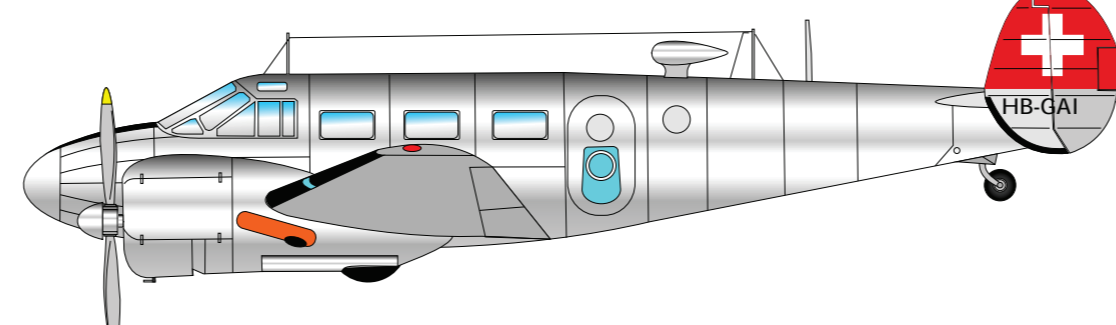

Beech C-45F
1948 bis 1967 / 13 Stück

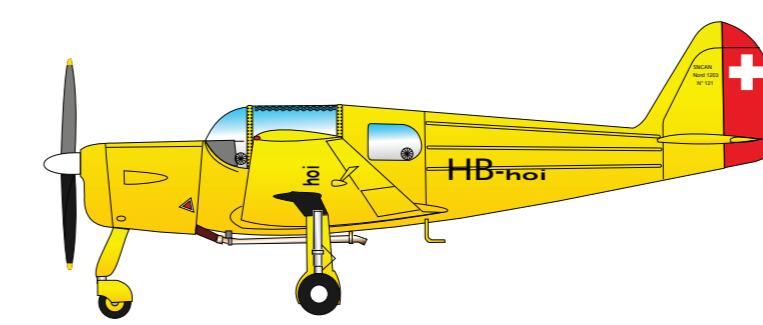

Nord 1203 «Norécrin»
1948 bis 1954 / 1 Stück

- Beschaffte Flugzeuge
- Prototyp/Testflugzeug
- Internierte Flugzeuge

1m 5m

Massstab 1:86
Gezeichnet: ©Stefan Keller 4.2.2010